 VETTER GMBH Kabelverlegetechnik D-79807 Lottstetten	Freimaß-Toleranz nach ISO 2768-1 mittel / -2 K	Oberflächen DIN ISO 1302	Maßstab	Position	Menge
			Werkstoff		
	Datum	Name	Kabeltransport-Anhänger Cable drum trailer Remorque pour le transport de câble Remolque para el transporte de cable		
gez.	04.12.09	Hornung			
gepr.	12.09.2011	W. Saum			
	Norm				
3	Aktualisierung	12.09.11	Hornung	KVS 1000 342.090.01-3	
2	Aktualisierung	22.02.10	Hornung		
1	Aktualisierung	19.06.09	Hornung		
Zustand	Änderung	Datum	Name	Gewicht:	Größe:

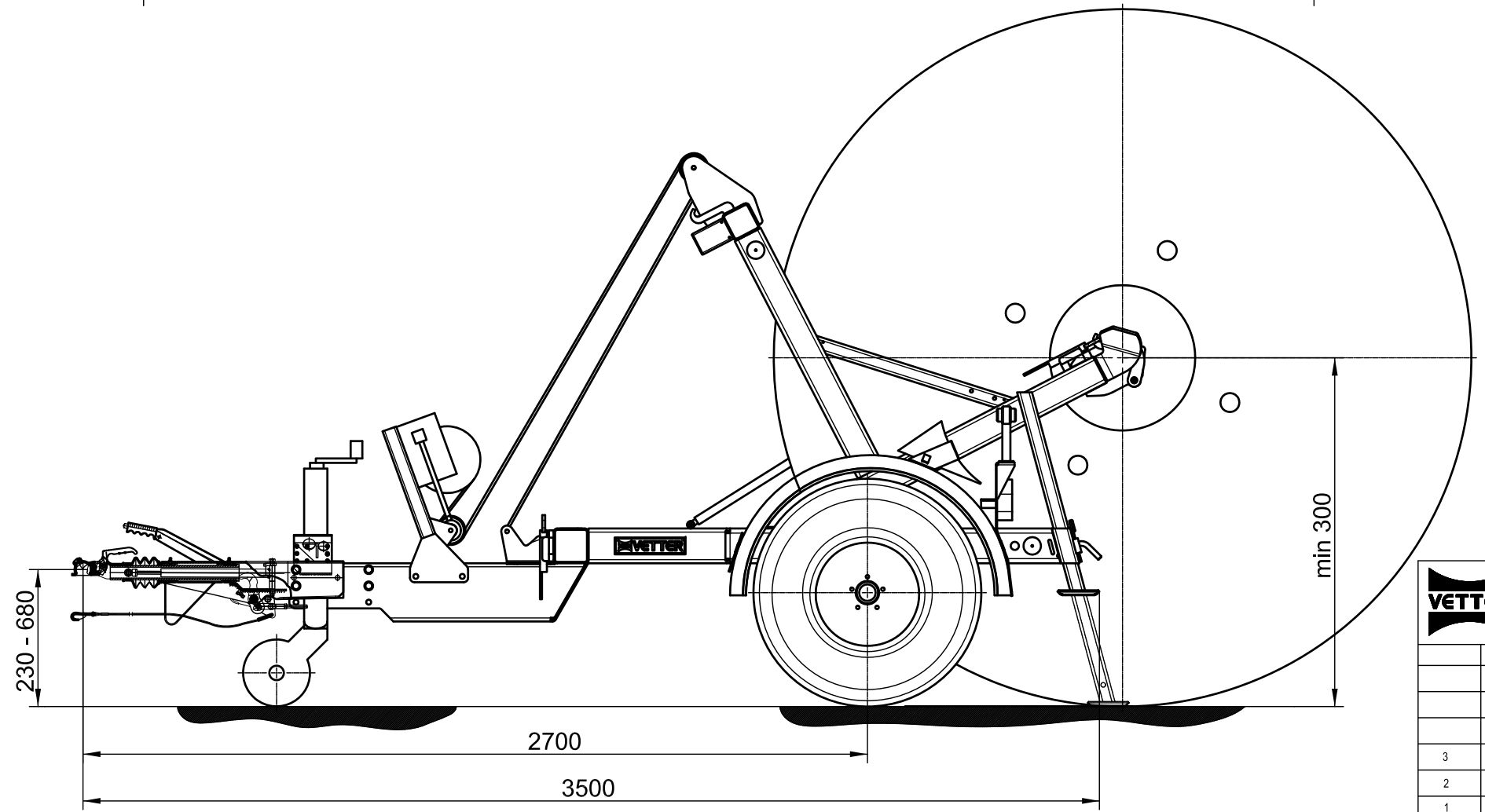
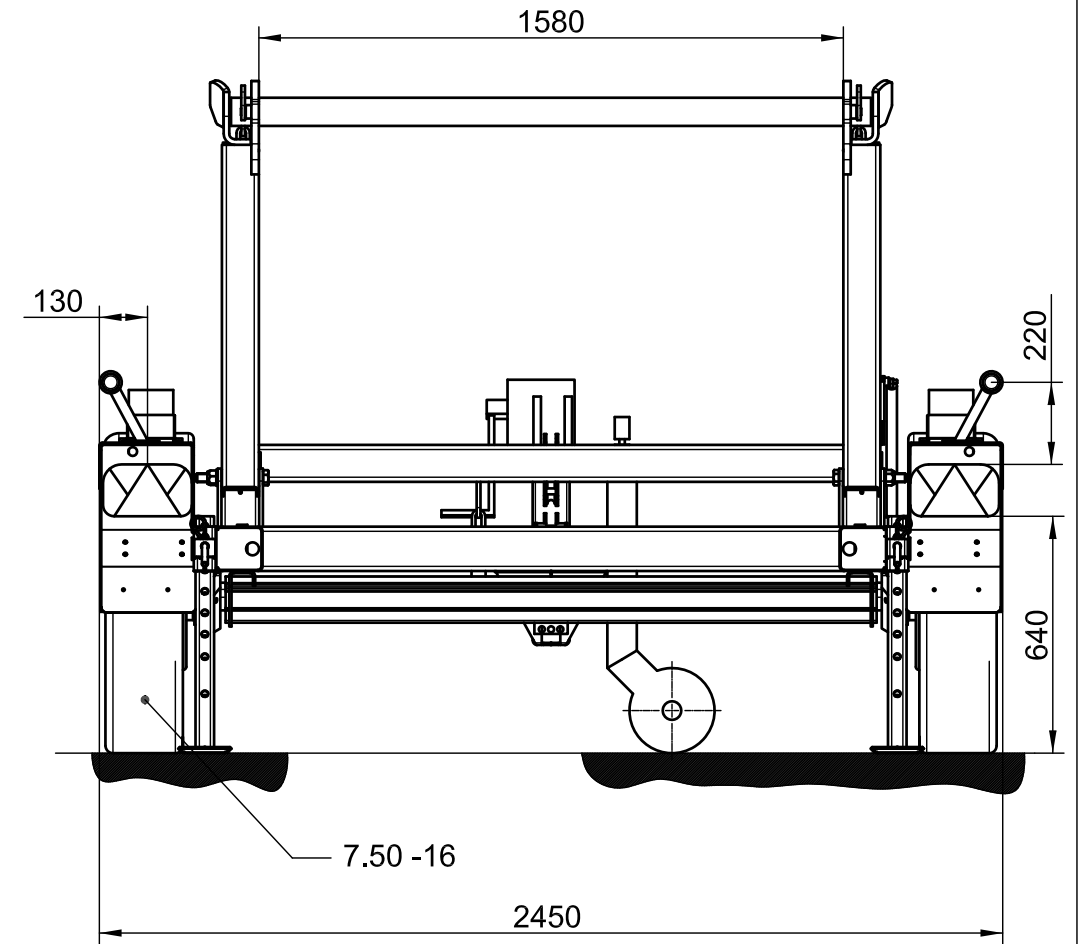
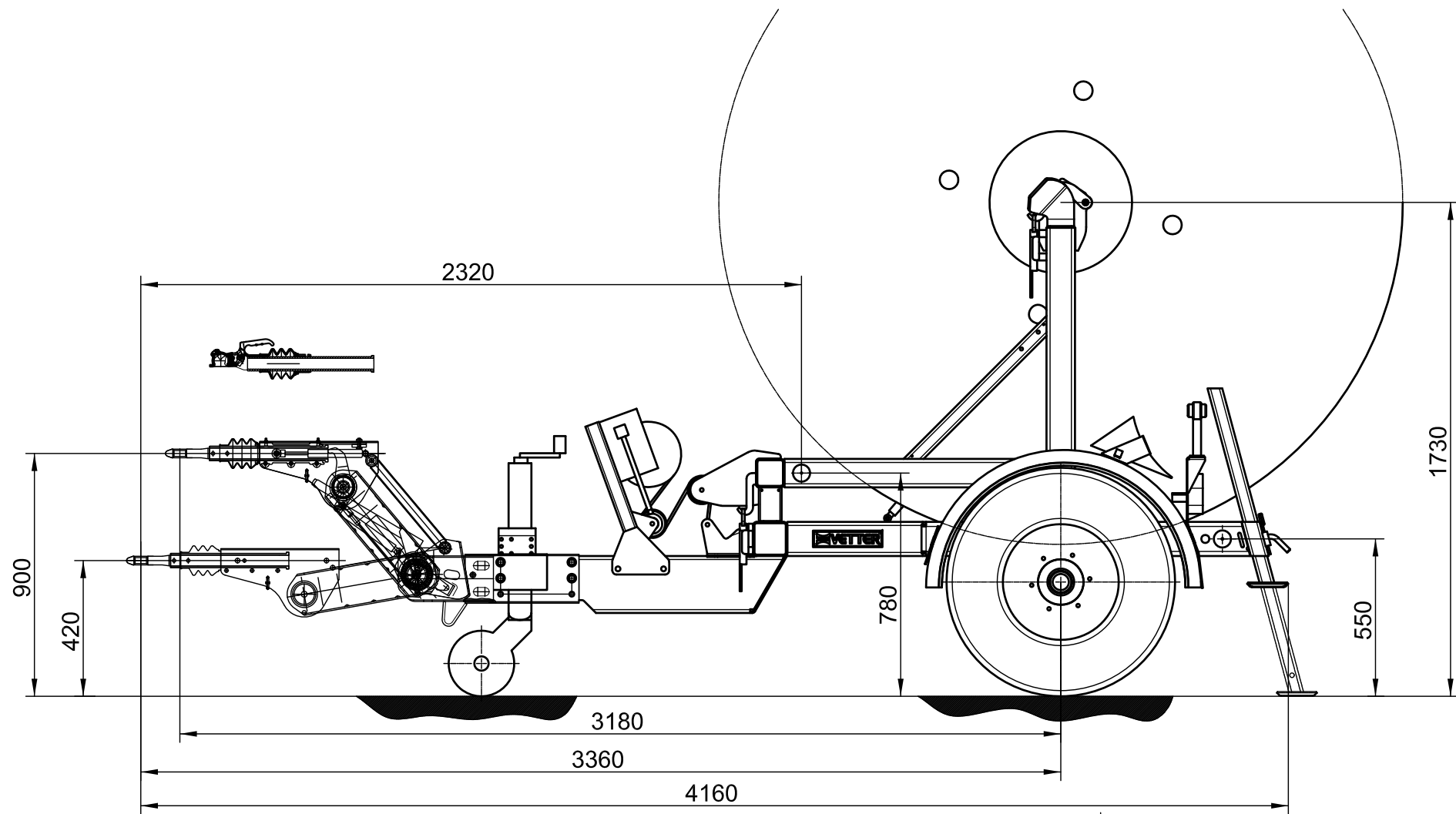

VETTER VETTER GMBH Kabelverlegetechnik D-79807 Lottstetten		Freimaß-Toleranz nach ISO 2768-1 mittel / -2 K	Oberflächen DIN ISO 1302	Maßstab Werkstoff	Position	Menge
		Datum	Name	Kabeltransport-Anhänger Cable drum trailer Remorque pour le transport de câble Remolque para el transporte de cable		
		gez. 04.12.09	Hornung			
		gepr. 12.09.2011	W. Saum			
		Norm				
3	Aktualisierung	12.09.11	Hornung	KVS 1500 / 2000		
2	Aktualisierung	22.02.10	Hornung			
1	Aktualisierung	16.09.09	Hornung			
Zustand	Änderung	Datum	Name	Gewicht:		Größe:
				342.131.01-3		Bl. v.